

UM SERIES Low Cost Utility Flowmeter

Features

- Provides a compact & economical flow metering solution for low viscosity liquids
- 3/4" (20mm) quick couple process connections
- Wide flow range 1 ~ 70 litres/min (0.3 ~ 18 US gal/min)
- Accuracy better than +/- 2% o.r.
- Repeatability better than 0.3% o.r.
- Hall Effect & Reed Switch outputs giving 30 ppL (114 p/US gal)
- 2°C ~ 90°C (35°F ~ 195°F) operation
- 10 bar max. operating pressure
- Low pressure loss suits gravity flow installations
- Integral strainer included
- Robust IP66 (Nema 4X) construction
- Available as a blind meter with dual pulse outputs or with integral self powered Flow Rate and Totaliser displays (See RT and BT data sheets)
- Batch controller version available (See ES Ecobatch data sheet)



Overview

The UM series flowmeter is specifically engineered for monitoring or controlling the movements of small to medium volumes of water, diesel fuels, or non-volatile low viscosity liquids in small pipe sizes.

The UM series is available in either blind configuration with dual pulsed outputs (Hall Effect & Reed Switch) or with an onboard self powered register to display rate, total, batch total or the meter can be fitted with an integral batch controller.

Utilising the proven inferential impeller measuring principle, the UM will tolerate liquids bearing a degree of suspended solids, where larger particles are captured by an integral inlet strainer screen which is accessible for periodic inspection.

3/4" BSPM or NPT threaded close coupled process connections combined with integral flow conditioning ports eliminates the need for straight run piping sections to simplify installation requirements. Nickel plated brass construction offers protection against corrosion.

Rate Totaliser Options

The register versions have easy to read LCD display for Flow Rate, Resettable & Accumulated totals. Scaleable pulse and 4~20mA analogue outputs, high and low flow alarms are also available. A 10 point non linearity correction option is available to improve the overall accuracy to within +/- 0.5% of reading.

Batch Control Options

The meter can also be fitted with a batch controller or supplied as a complete batch control system including solenoid valve.

UM020B#	blind meter with Reed switch & Hall effect outputs	0.8 Kg
UM020B# - R1	meter with RT11 rate totaliser (with scaleable pulse output)	1.0 Kg
UM020B# - R2	meter with RT12 rate totaliser (RT11+ 4~20 mA & alarms)	1.0 Kg
UM020B# - E0	meter with 24vdc powered Ecobatch batch controller	1.0 Kg
UM020B# - ES0	meter with 24vdc Ecobatch & 24vdc x 8W solenoid valve	2.0 Kg
UM020B# - B0	meter with BT10 totaliser	1.0 Kg
UM020B# - B1	meter with BT11 totaliser	1.0 Kg

select according to process connections (1 = 3/4" BSP. 2 = 3/4" NPT)

UM020 Specifications :

Body	: Brass (External chrome plating)
Process Connections	: 3/4" BSP or NPT male (adaptors)
Flow	: 60 – 4200 litres / Hr
Accuracy	: +/- 2% o.r. (0.3% o.r. repeatability)
Max. Pressure	: 10 bar
Max. Temperature	: 90 °C (80 °C with integral displays)
Output resolution	: 30 Pulses/Litre (114 P/USG)
Output types	: Hall Effect (NPN open collector) or Reed Switch

Terminal Designations

	: Reed Switch (24VDC / 50mA max)
VDC	: +DC Voltage (8~24VDC)
+Π SIG	: Pulse output (20mA max sink current)
-0V	: 0 VDC

Dimensions (shown as blind & with RT rate totaliser)

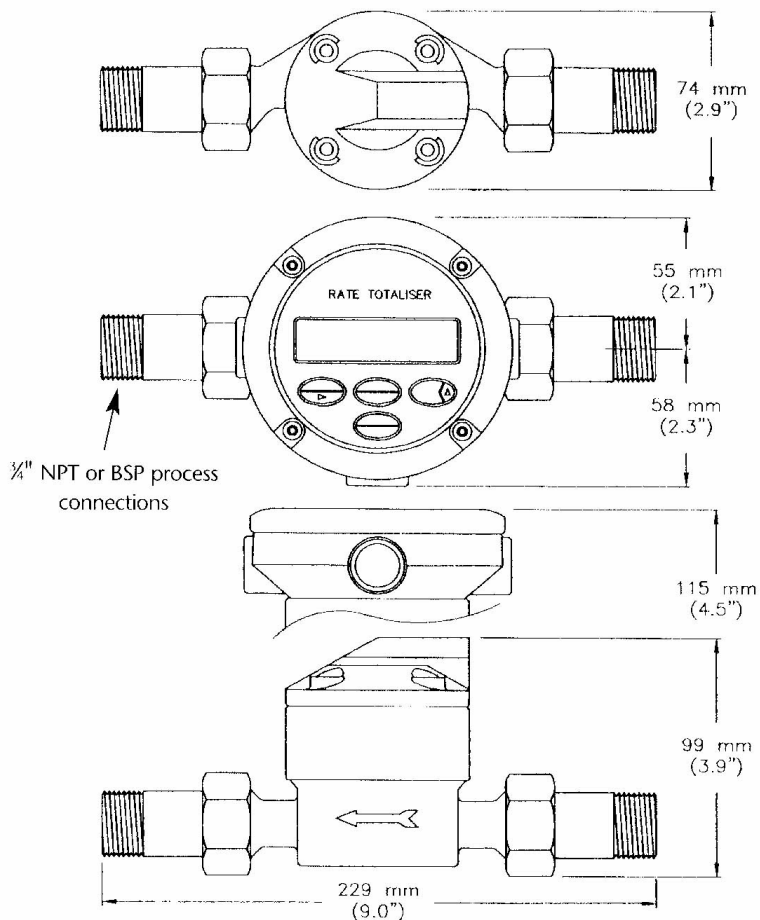

PC Board within meter

